

Harmonic Reject Filter

Miniature low pass filter

IPD technology

Passes GSM 880-960MHz band

Rejects 2,3,4 harmonics

Filter specifications

- Typical application :
 - Passes GSM low band (880-960MHz)
 - Rejects harmonics (n=2,3,4)
- Low Insertion Loss
 - IL < 0.7dB @ 800 -1000MHz
- High Rejection of 2,3,4 Harmonics
 - Rejection > 40dB @ 1760-38400MHz
- 50 Ohm Input Output Impedance
 - Return Loss < -17dB @ 880-960MHz

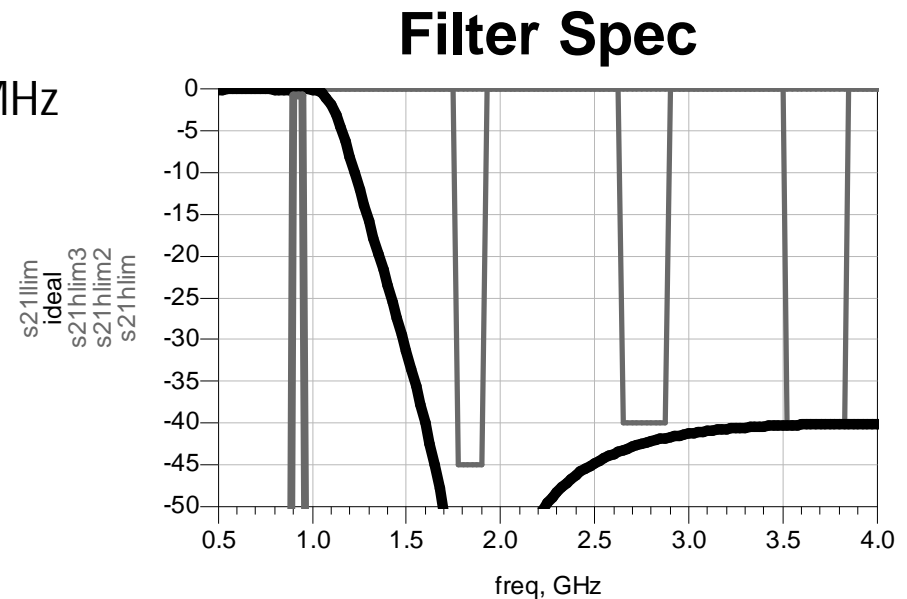

Design steps 1,2,3,4

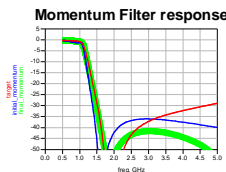
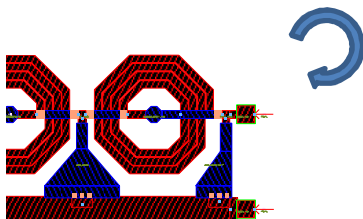
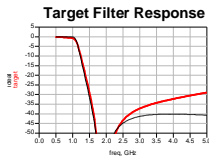
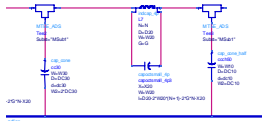
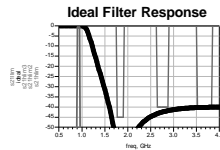
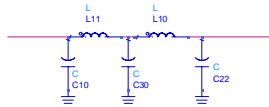
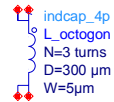
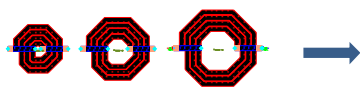

1. Build a parameterized component library
 - Simulate the Inductor and capacitor components using Momentum 2.5D simulator with respect to the object's geometry (Width, Diameter, Number of turns, ...)
 - Optional :Extract Equivalent Model parameters for each geometry
 - Build a Parameterized Simulation model based on individual geometries

2. Choose a filter topology (Chebyshev for ex) with ideal lumped components.
 - Optimize L,C components values to match specifications
 - Save *Ideal* S-parameter filter response

3. Generate the target schematics
 - with the parameterized library component based on the filter topology
 - Tune / Optimize the objects dimensions to match ideal S parameter response
 - Save *Target* S-parameter filter response

4. Preliminary layout / Fast Iterative process / Final Layout
 - Generate a preliminary layout and Simulate (Momentum)
 - Optimize the component dimensions in order to match the *Target* response.
 - Final momentum simulations
 - Gerber files generation

Step 1 : Parameterized Components 1/2

Spiral Inductors

Diameter = 350, 450, 550 μ m
Width = 40 μ m

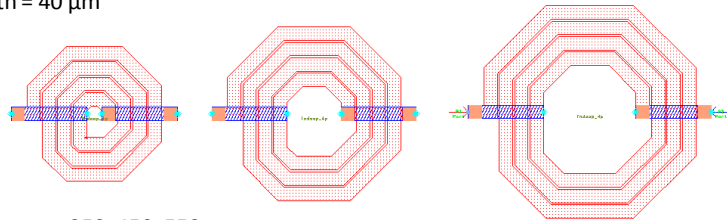

Diameter = 350, 450, 550 μ m
Width = 20 μ m

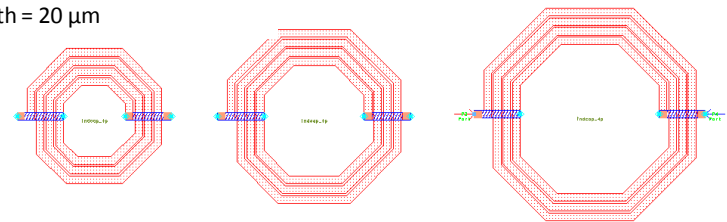

Capacitors

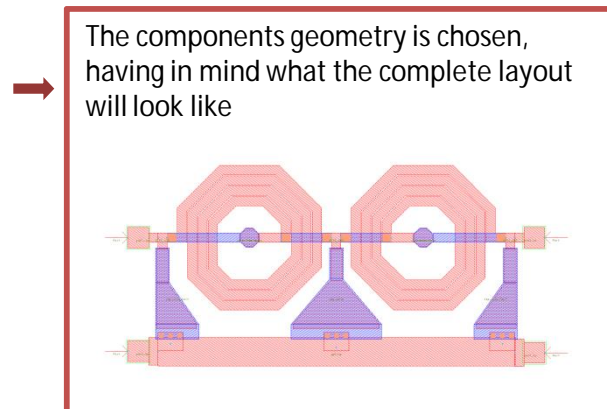
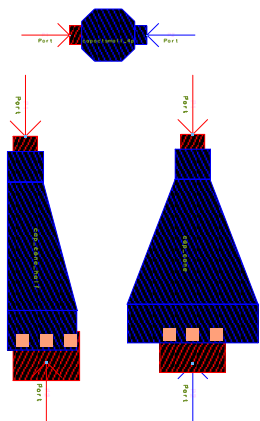

- Parameterized Black Box Model

- Automated process
- Perform Momentum simulations of inductors and capacitors for a set of geometries covering the target component values.
- Merge the corresponding momentum simulation results in a single file
- Ready for Fast interpolated simulations.

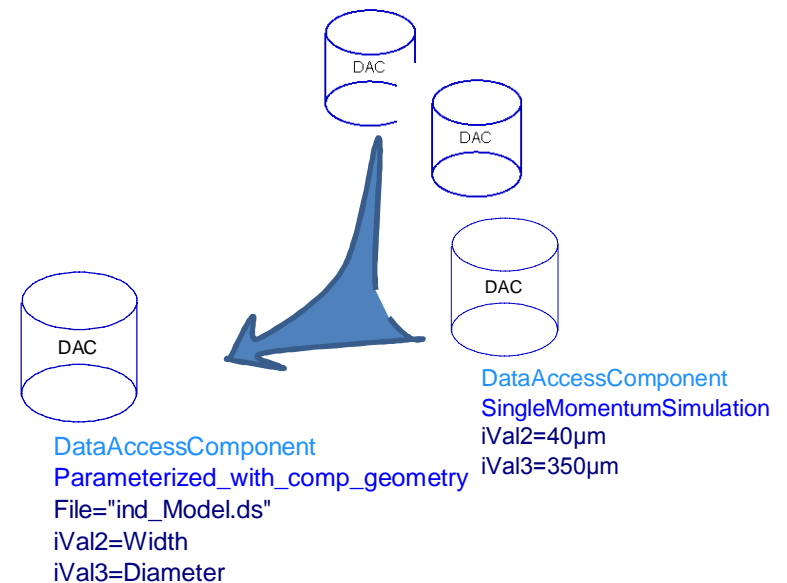

Step 1 : Parameterized Components 2/2

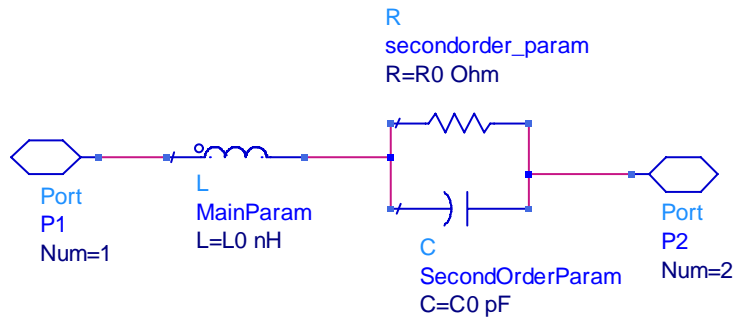

- Fitted lumped element model
 - Fit model to momentum simulation results
 - Get extracted parameters for each geometry
 - Main parameter L0
 - Second order : R0, C0
 - IPD technology : small parasitics

Actual "ideal" simulation is based on main parameters only (L0)
Use a second order model (R0,C0) next time

Main Model parameters : L0

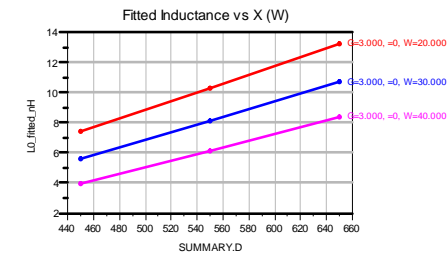
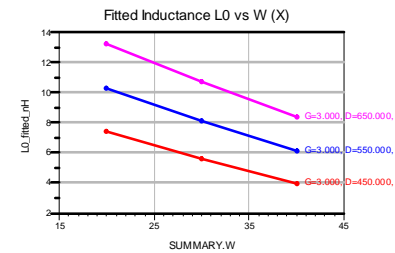

Secondary Model parameters : R0, C0

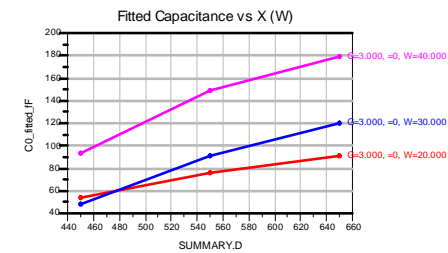
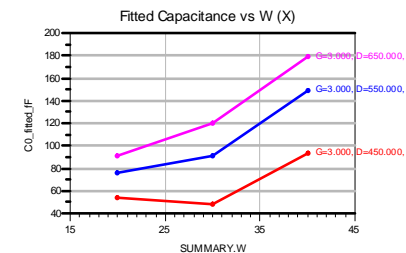
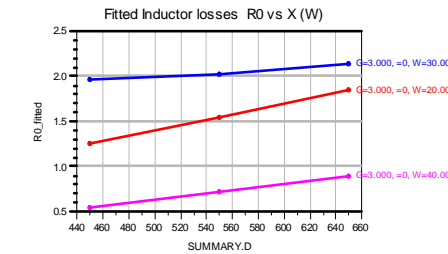
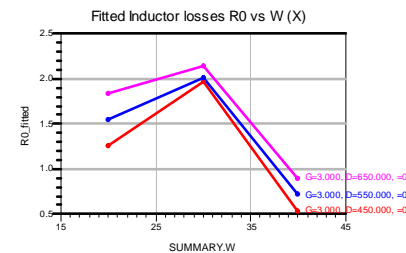

Step 2,3 Schematics

Ideal Model : Lossless Lumped Components

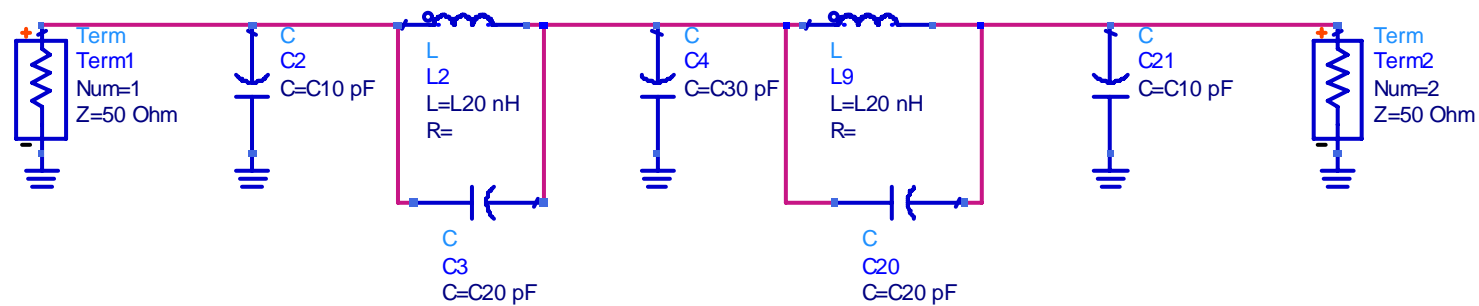

Target model : Geometrically Modeled Components

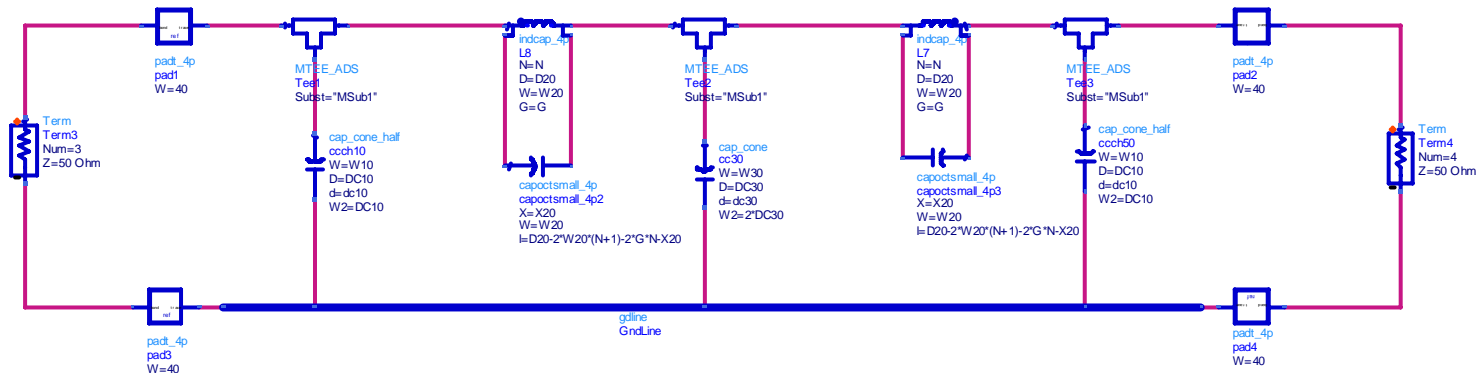

Step 2,3 : Build Ideal and Target

Target Filter Response

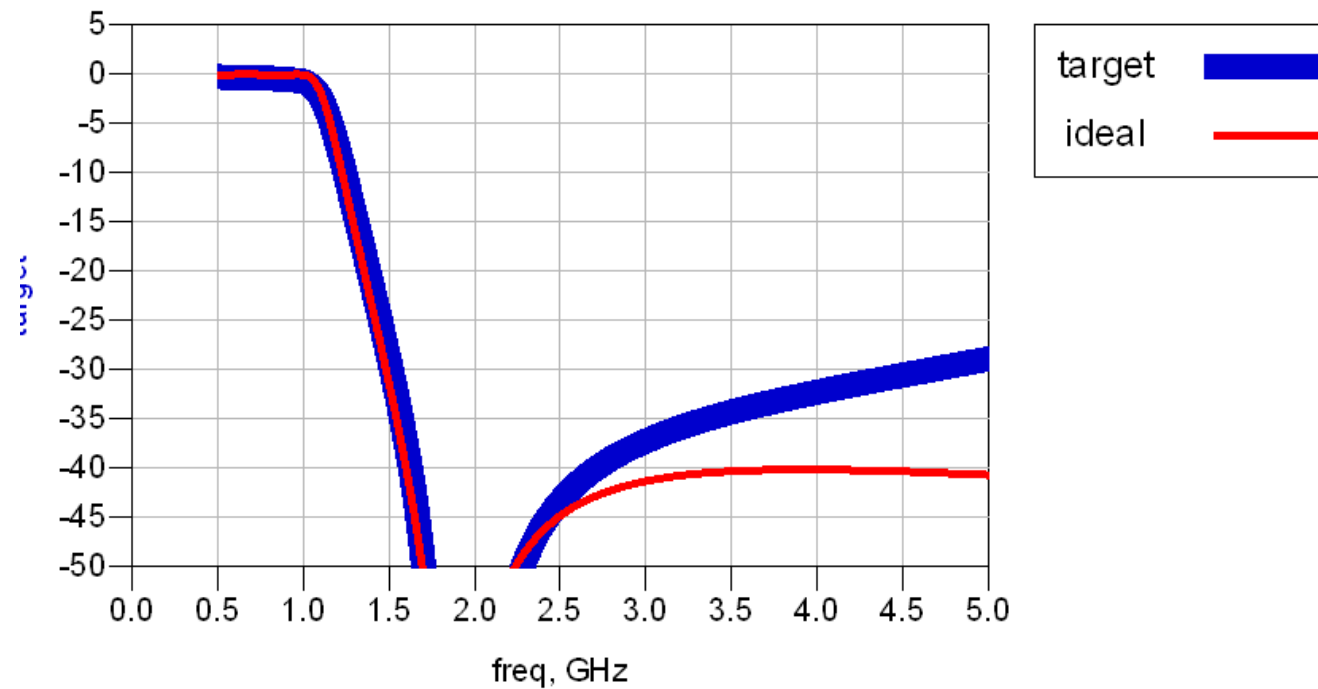

Step 4 : Initial layout

1. Create the layout of the complete circuit
2. Run Momentum simulations

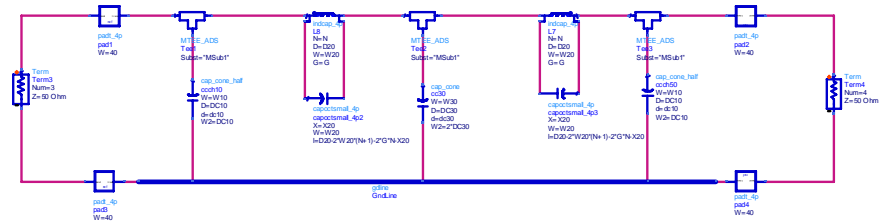

Auto Layout

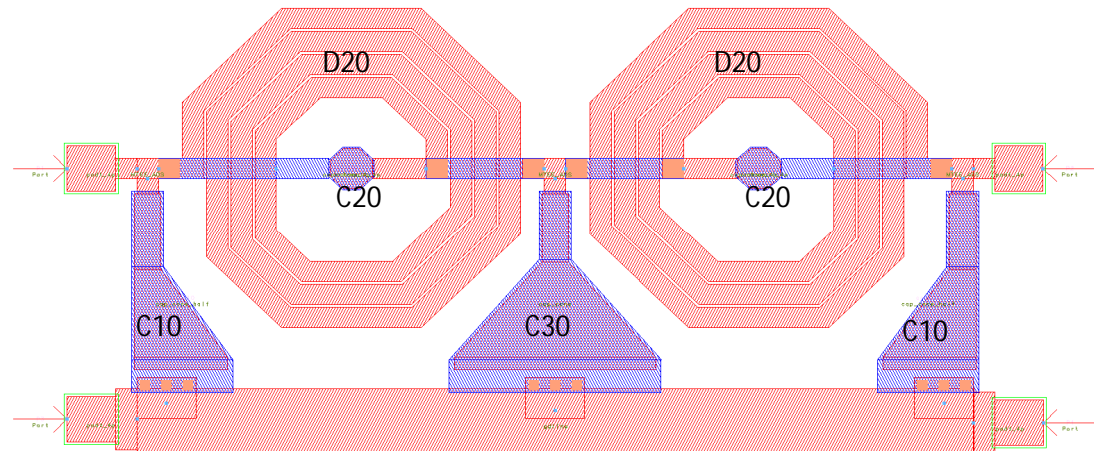

Steps 4 : Momentum Simulations reach Target

Filter response

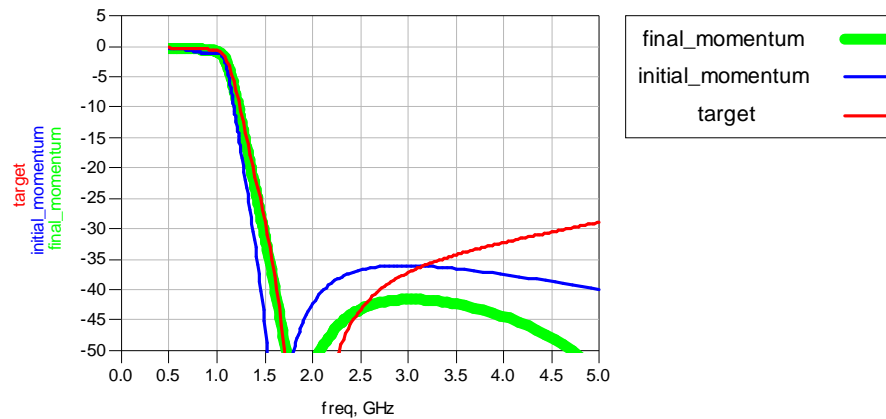

Filter Losses

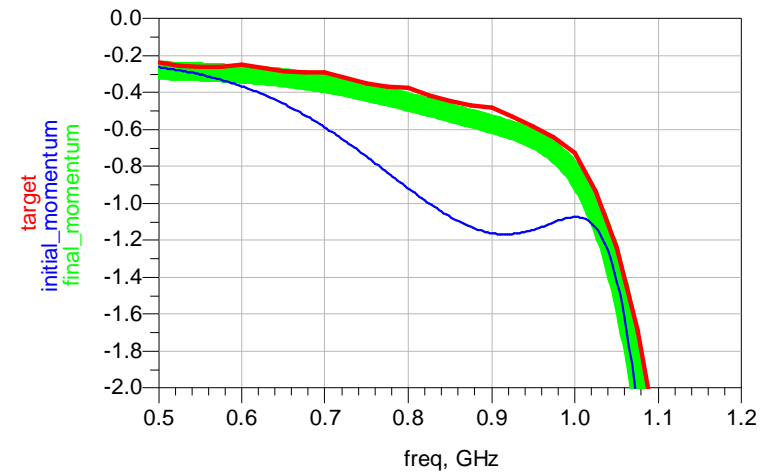

Filter return losses

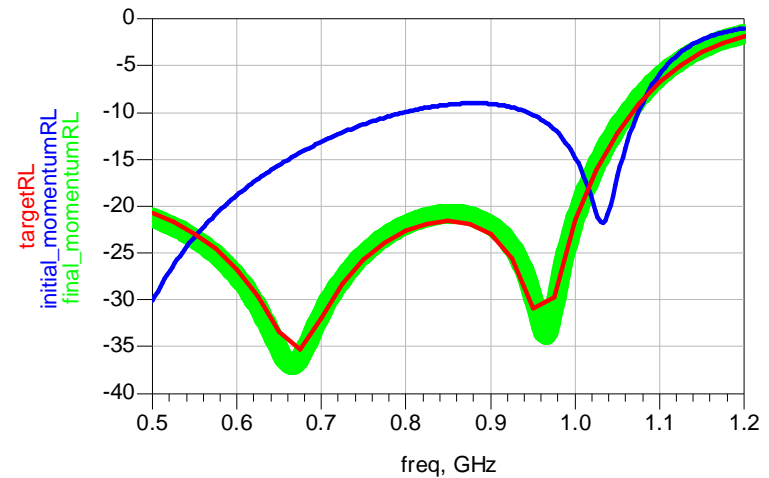

➔ After a Fast Iterative Process, final momentum simulations reaches target S parameters.

Step 4 : Intermediate Results

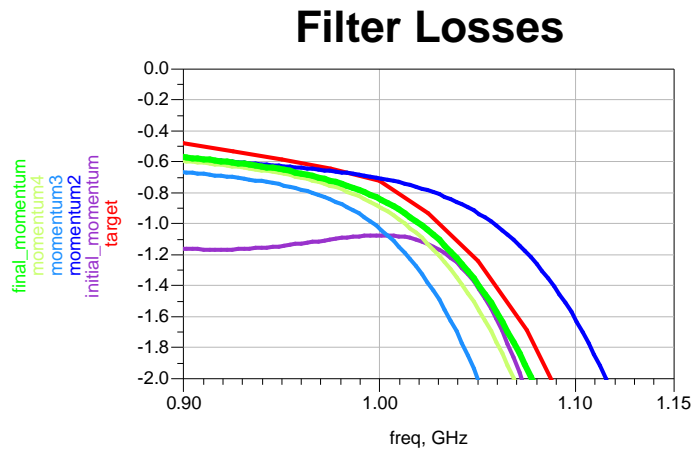
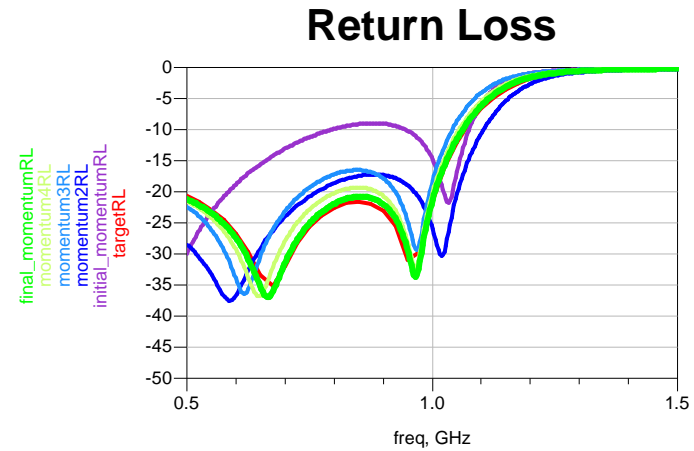
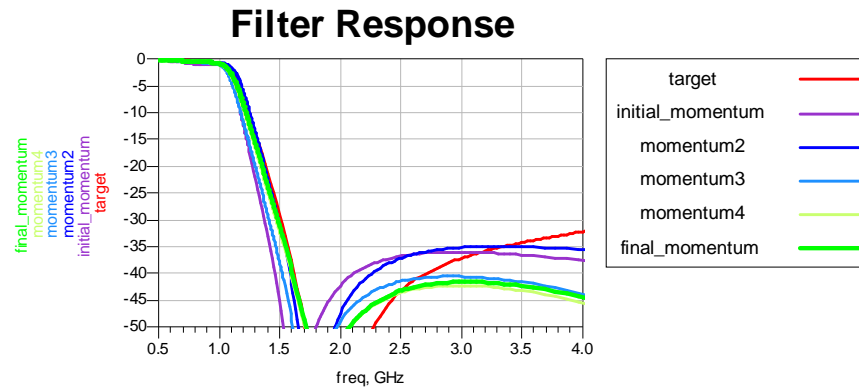

	C20 capacitor dimension	L20 Inductor diameter	C10 capacitor dimension	C30 capacitor dimension
step	X20 μm	D20 μm	DC10 μm	DC30 μm
initial	103	650	185	153
mom2	114	671	200	125
mom3	92	636	183	185
mom4	84	635	178	188
final	84.7	629	173	187.3

Final Layout / Results

Filter Response

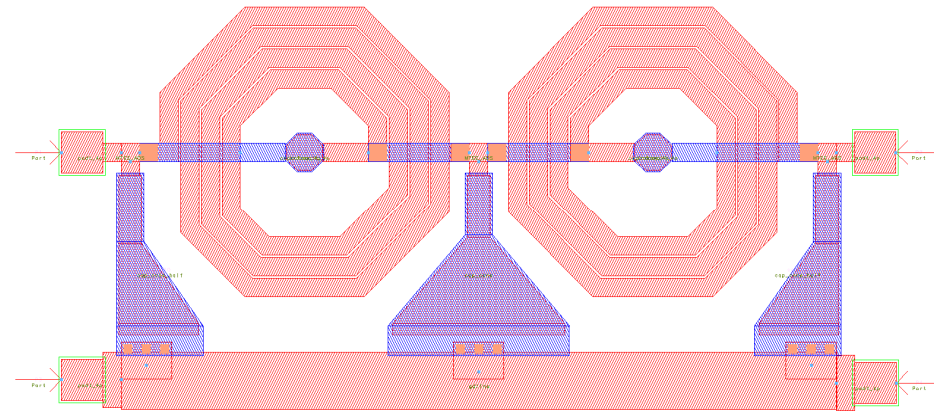
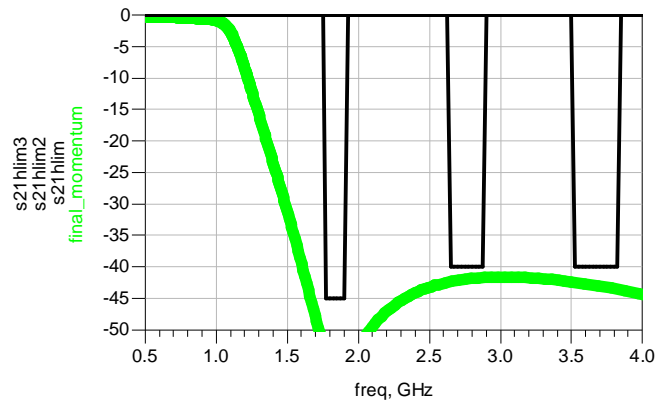

IPD Filter Dimensions :
 $1.6\text{mm} \times 1.1\text{mm} = 1.76\text{mm}^2$

Filter Losses

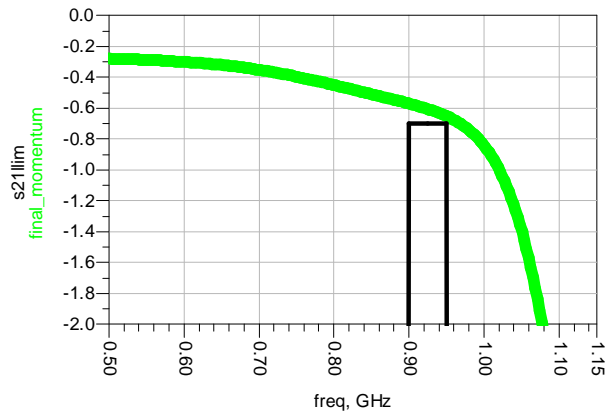

Return Loss

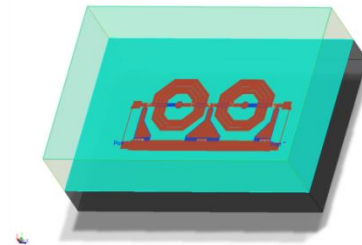
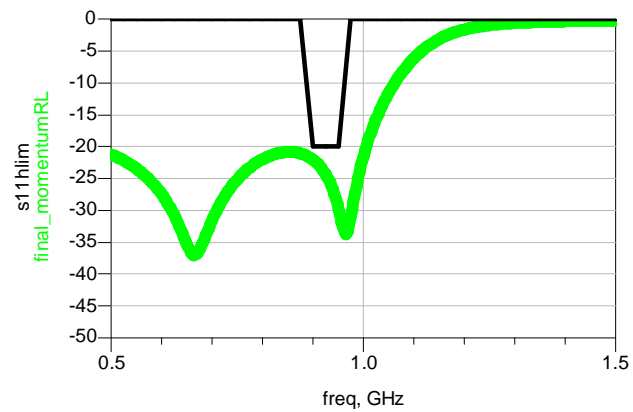

Filter Design Conclusion

- GSM harmonics filter designed in IPD technology
 - Small overall dimensions
 - $1.6\text{mm} \times 1.1\text{mm} = 1.76\text{mm}^2$
 - Performances meet specification
 - $<0.7\text{dB}$ insertion loss,
 - $> 50\text{dB}$ rejection (2nd Harmonic)
 - $> 40\text{dB}$ rejection (3rd and 4th Harmonics)
 - $<-20\text{dB}$ return loss.
- Simple and Powerful Design methodology.
 - From schematics to layout in small reversible steps
 - Geometry optimization through a Fast Iterative Process using a small number of intermediate momentum simulations.