



Wednesday February 18, 2015

**BLUETOOTH SMART[®] SOLUTIONS FOR TINY
METAL OBJECTS
TECHNICAL TRADE OFF AND SOLUTIONS**

*Chris Barratt - Michel Beghin
Insight SiP France*



AGENDA

- ▶ Insight SiP
- ▶ Introduction
- ▶ Metal Case Connected Watch
 - Metal Case Description
 - Design process
 - Design Example
 - Performance
 - Link Budget
- ▶ In-ear Hearing Aid
 - Design Example
 - Performance
 - Link Budget
- ▶ Conclusions

AGENDA

- ▶ **Insight SiP**
- ▶ *Introduction*
- ▶ *Metal Case Connected Watch*
 - *Metal Case Description*
 - *Design process*
 - *Design Example*
 - *Performance*
 - *Link Budget*
- ▶ *In-ear Hearing Aid*
 - *Design Example*
 - *Performance*
 - *Link Budget*
- ▶ *Conclusions*

Insight SiP

- ▶ Established in 2005
 - Core team from National Semiconductor
- ▶ Experts in RF System-in-Package (SiP)
 - Design & industrialization expertise
 - Fab-less company
- ▶ Product Lines
 - Providing turn-key design services and creative packaging solutions
 - Providing standard modules for wireless electronic industry
- ▶ Locations
 - Europe – Technical team at Sophia-Antipolis - France
 - North America – Subsidiary in Denver since 2008
 - Asia – Sales office in Tokyo since 2008



SiP Expertise

▶ Core Competencies

- Any Wireless connectivity to fit any device space
- System-in-Package (SiP) design approach
- Highly integrated antenna design expertise
- Unique methods to estimate package size and performance
- Optimization Size/Cost/Time to Market
- Multiple Technologies : BT, FR4, LTCC, HTCC, Thick Film, PCB, IPD,...
- Multiple Assembly Methods: SMT, Wirebond, Flipchip, Embedded Dies...

▶ Technical Successes

- 3G, ANT, BLE, Bluetooth®, GSM/W-CDMA, GPS, ISM, LTE, NFC, RFID, UMTS, UWB, WHDI™, WiFi, WLAN, Zigbee® ...

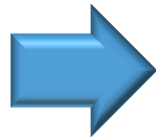
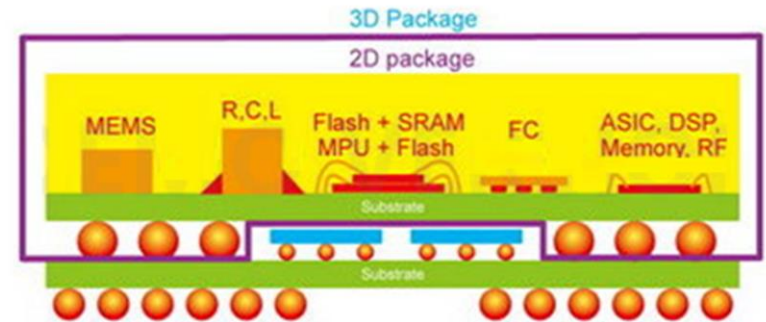

Benefits to our customers
Smaller, Faster, Lower Cost

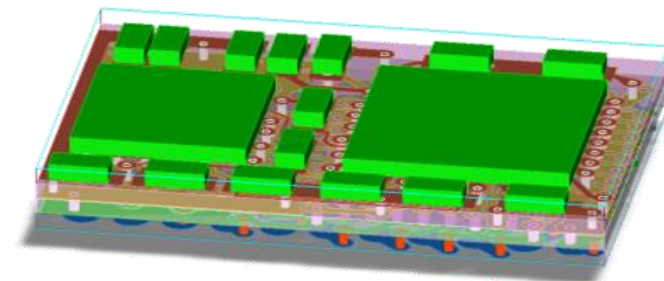

AGENDA

- ▶ *Insight SiP*
- ▶ **Introduction**
- ▶ *Metal Case Connected Watch*
 - *Metal Case Description*
 - *Design process*
 - *Design Example*
 - *Performance*
 - *Link Budget*
- ▶ *In-ear Hearing Aid*
 - *Design Example*
 - *Performance*
 - *Link Budget*
- ▶ *Conclusions*

Introduction

▶ Bluetooth Smart

- Dominant Standard for short range communication
 - Reduced power consumption of individual functions $< 10\text{mA}$ radio



Mostly Off



Introduction 2

- ▶ Bluetooth Smart
 - Block Diagram

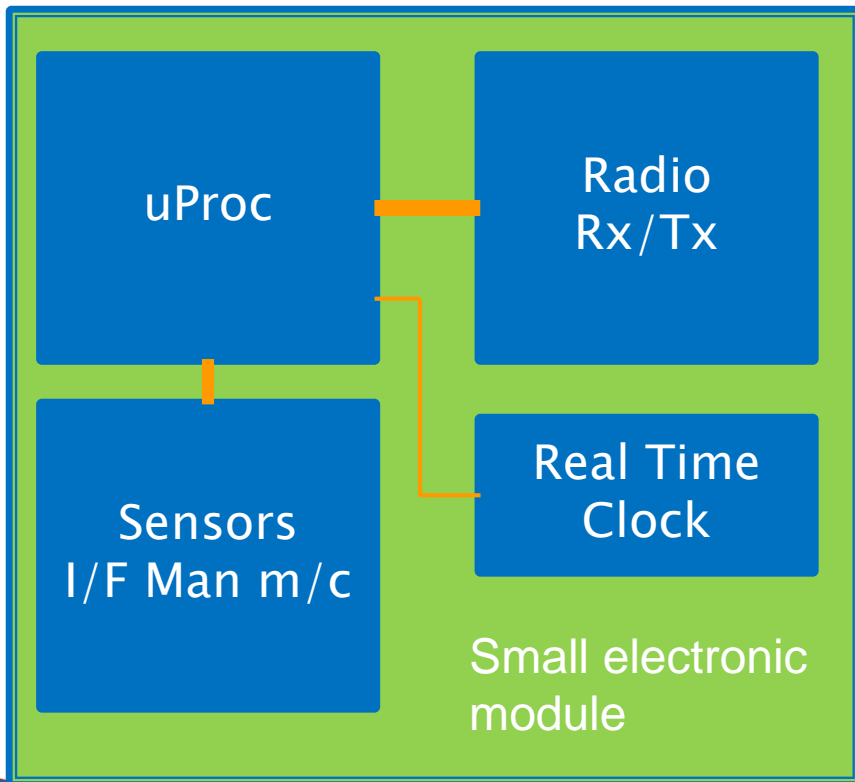

Antenna



Small is beautiful
BUT
Will it Work?

Module or Discrete ?

- ▶ Need to check overall project cost and duration between both solution

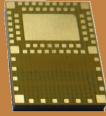
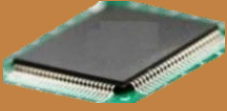
	Module  	Chip + Discrete 
RF design	Core competency of module vendor Heavy 1-time investment	Expertise required for layout, signal routing, layer stack-up, interference, shielding
Size	Optimized size	Non module may require larger area on target PCB
Procurement	1 component	Multiple components
Complexity	Like any component to place	RF design and RF yield
Assembly	1 component ready to mount	Complex Bill Of Material (BOM)
Test	Module fully tested (behaviour, Electromagnetic, placement,...)	Need full test on end-product
Yield	100% yield ready modules	Yield losses in production Failure analysis & rework costs
Quality	Modules are fully tested and provided as known good	RF expertise and test flows to cover connectivity systems
Certification	Pre-certified / already certified	Certification from scratch

Module or Discrete ?

- ▶ Insight SiP intends to propose a **complete BLE solution offer** to our customers

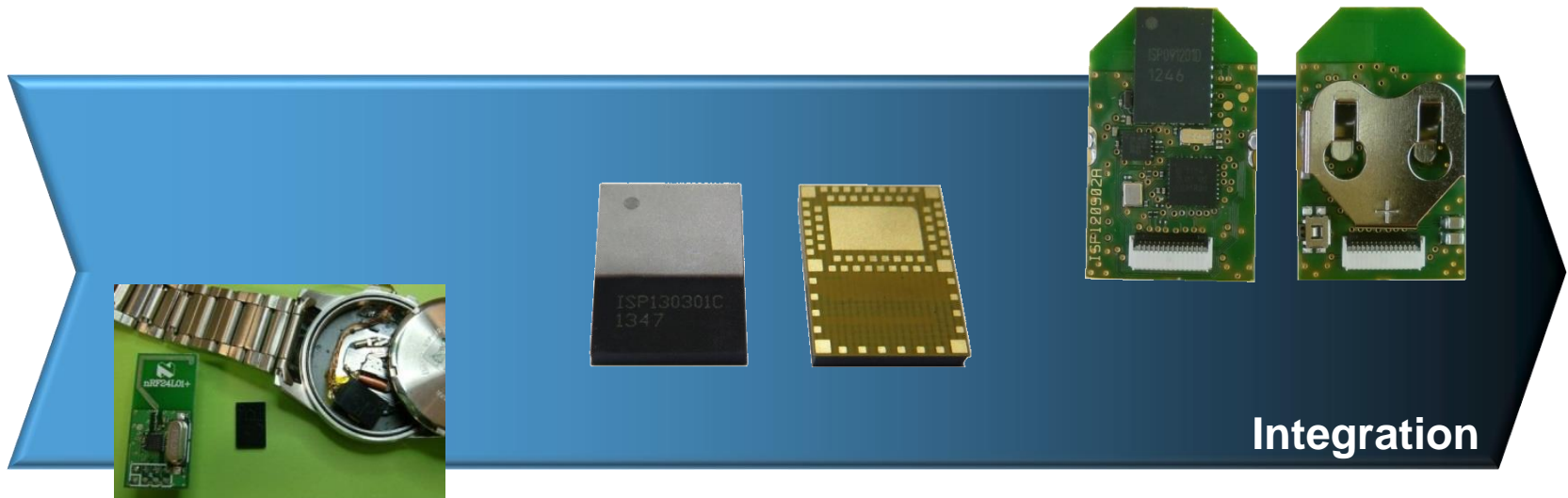

✚ Discrete solution

- ✓ Radio and application both designed on customized circuit

✚ Module solution

- ✓ Radio included in a module integrated on application circuit
- ✓ Custom or Off shelf

✚ Sensor solution

- ✓ Ready to Use
- Radio and Hardware circuit
- ✓ Custom or Off shelf

AGENDA

- ▶ *Insight SiP*
- ▶ *Introduction*
- ▶ **Metal Case Connected Watch**
 - Metal Case Description
 - Design process
 - Design Example
 - Performance
 - Link Budget
- ▶ *In-ear Hearing Aid*
 - *Design Example*
 - *Performance*
 - *Link Budget*
- ▶ *Conclusions*

Metal Case Connected Watch

▶ Stylized Metal Watch Case

- 28 to 35 mm diameter
- Height 10 mm
 - Reduced power consumption of individual functions <10 mA radio
 - Electronics under movement
 - Antenna close to Electronics
 - Antenna near back plate

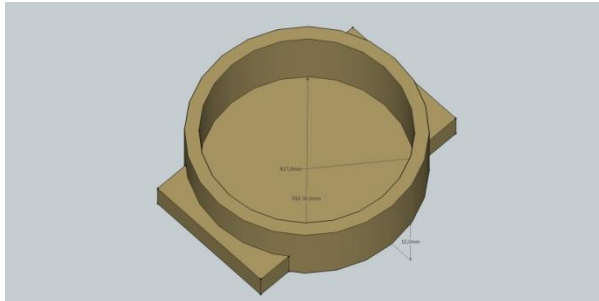

Mostly Plastic

All Metal



Design Process

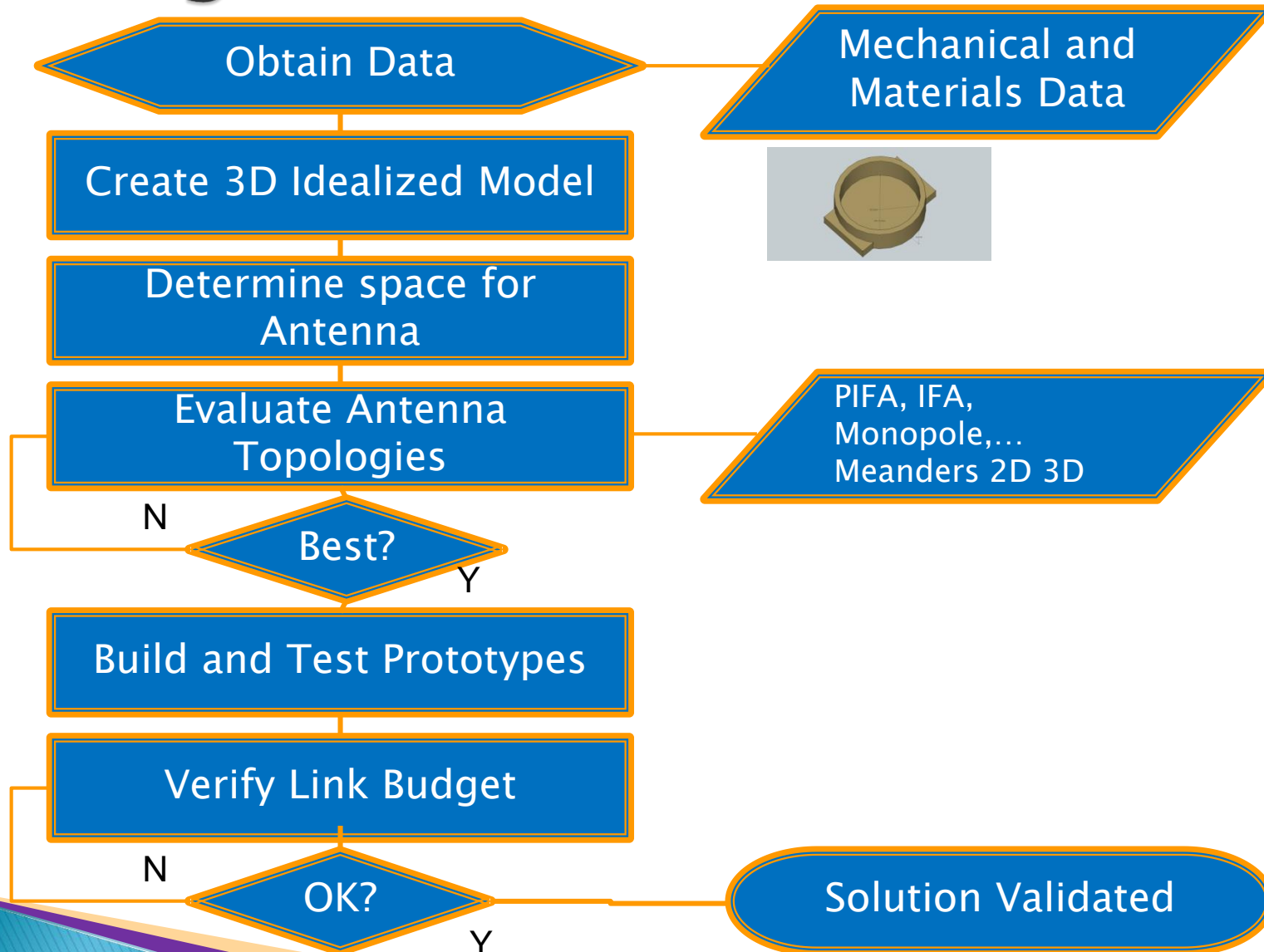

Design Example

- ▶ Constraints
 - Near watch back (2mm)
 - Small size ($<30\text{mm}^2$)
 - Near watch side walls
- ▶ Best Structure
 - PIFA 3D type

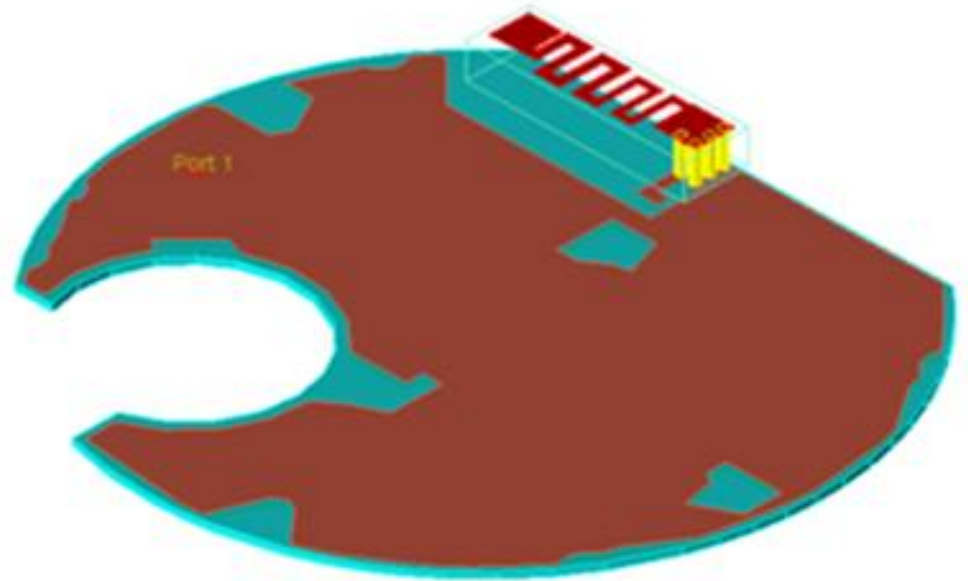

Optimum Performance

- ▶ Measured Prototype
 - Needs small re-centering
 - Gain ca -9 dBi
 - Return loss > 6 dB

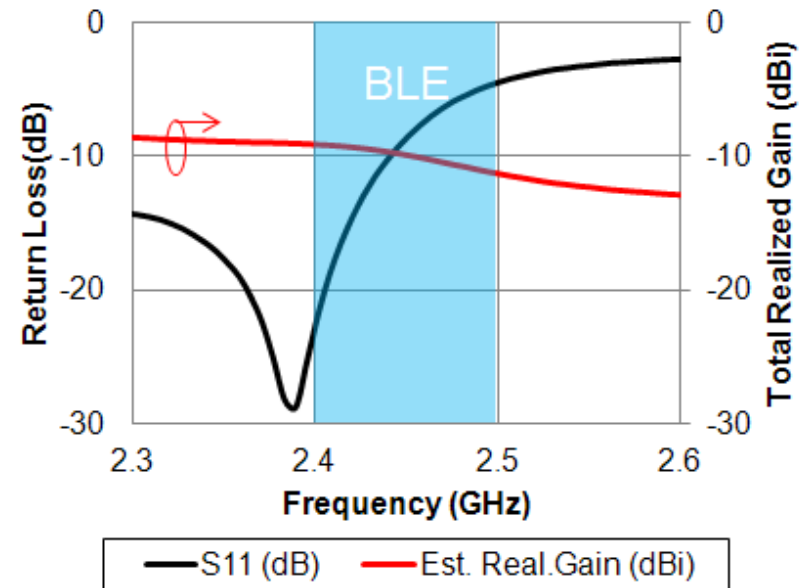

Link Budget

$$\frac{P_r}{P_t} = G_r G_t (1 - S_{11}^2)(1 - S_{22}^2) \left(\frac{\lambda}{4\pi R} \right)^2$$

Parameters

- P_t – Transmit Power *0dBm*
- P_r – Received signal at sensitivity level *-85dBm*
- G_t – Transmit Antenna Gain *0dBi*
- G_r – Receive Antenna Gain *-9dBi* (from measurements)
- S_{11} and S_{22} – *6dB Return Loss*
- λ Wavelength – *122cm*
- R – Range

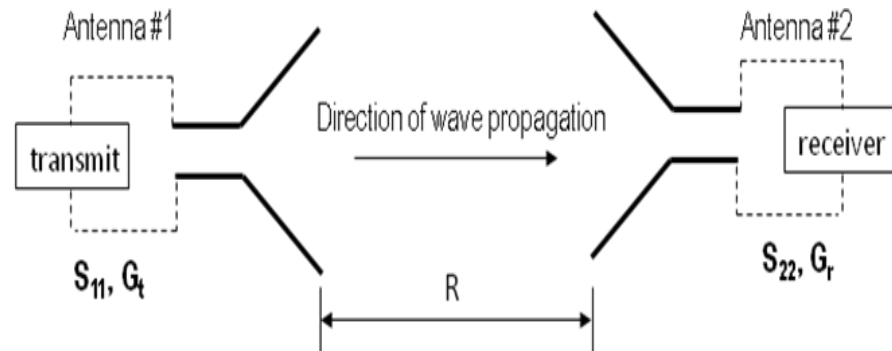

Link Budget as Function of Gr

- ▶ Link Budget
 - Bluetooth Smart
 - Cell Phone Gt 0dBi
 - Tx power 0dBm
 - Rx sensitivity -85 dBm
 - Slave antenna Gain Gr
 - Gr=-9dBi
 - Range 60m
 - Gr=-20 dBi
 - Range =18m

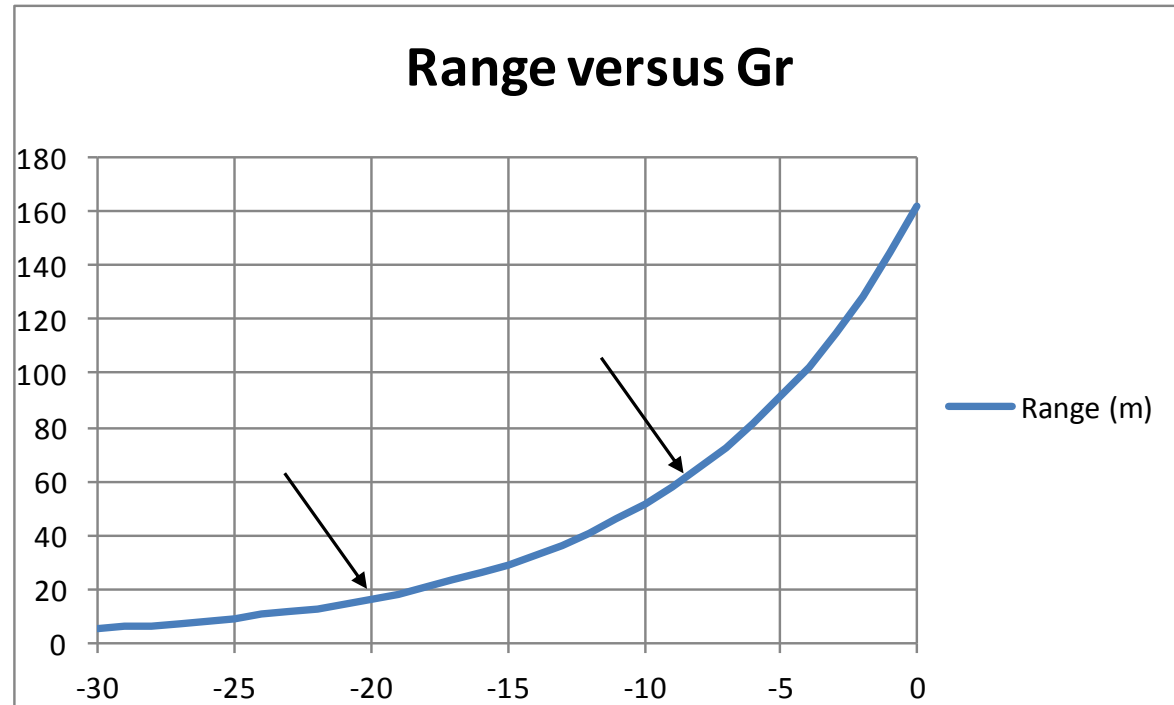

AGENDA

- ▶ *Insight SiP*
- ▶ *Introduction*
- ▶ *Metal Case Connected Watch*
 - *Metal Case Description*
 - *Design process*
 - *Design Example*
 - *Performance*
 - *Link Budget*
- ▶ **In-ear Hearing Aid**
 - **Design Example**
 - **Performance**
 - **Link Budget**
- ▶ *Conclusions*

In-Ear Hearing Aid

▶ In-Ear Hearing Aid

- Tiny Form Factor
 - Battery
 - Microphone
 - Loud Speaker
 - Electronics
- Bluetooth Smart
 - Add Antenna
 - It is inside the head
 - Must be very small



Design Example

- ▶ Major Challenges
 - Antenna space is tiny
 - Antenna is surrounded by absorbing soft tissue

Freq (MHz)	ϵ'_r	ϵ''_r	σ (S/m)	ϵ_r	$\text{tg } \delta$
2450	52.7	14.3	1.9	54	0.27

Simplified Human Head Model

- ▶ Head Model
 - Octagonal Prism
 - Filled with dielectric
 - Small Air Cavity = Ear

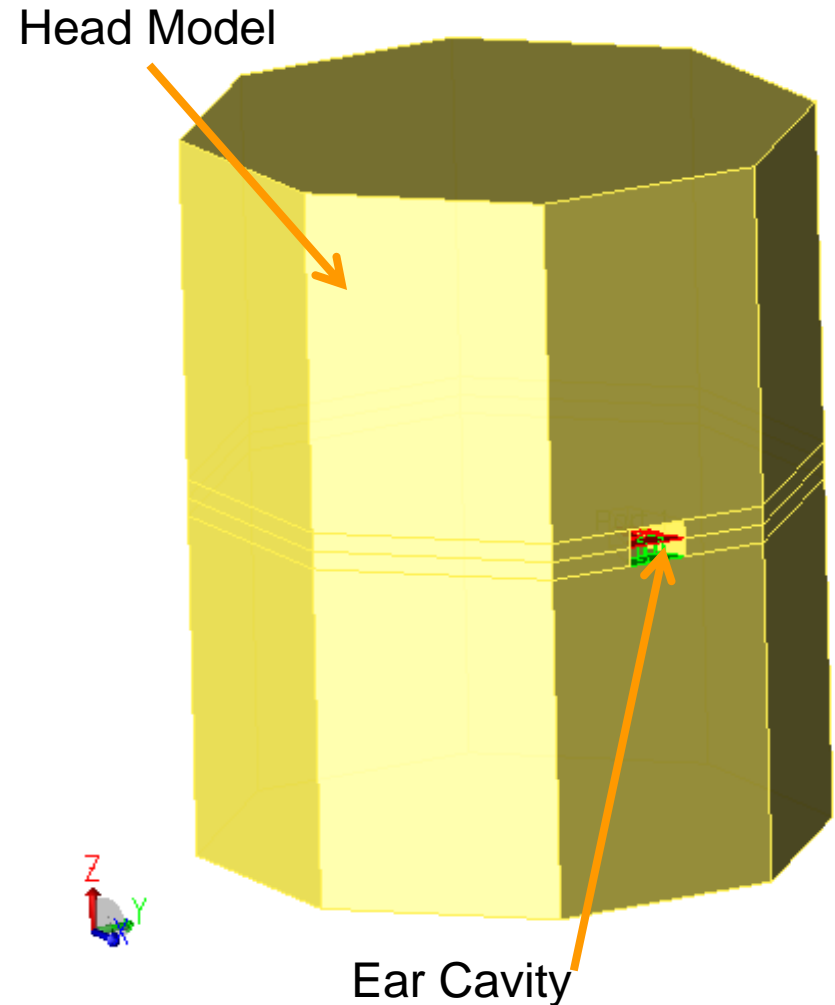

Optimum Performance

- ▶ Return Loss $> 6\text{dB}$ in band
- ▶ Total Gain $> -16\text{ dBi}$ in band

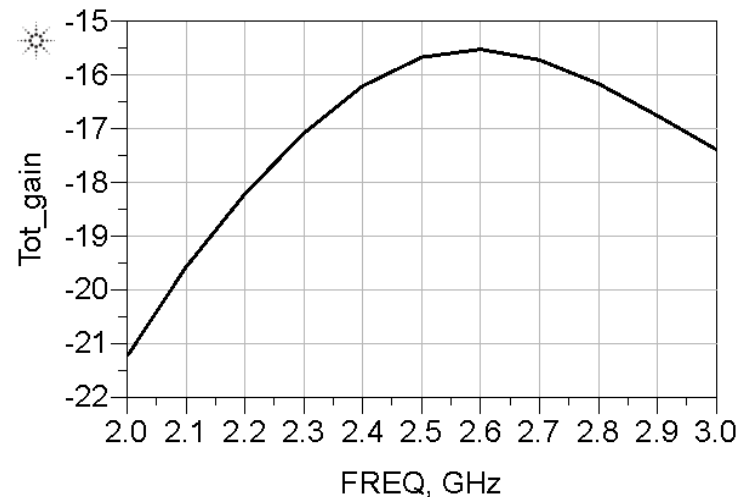
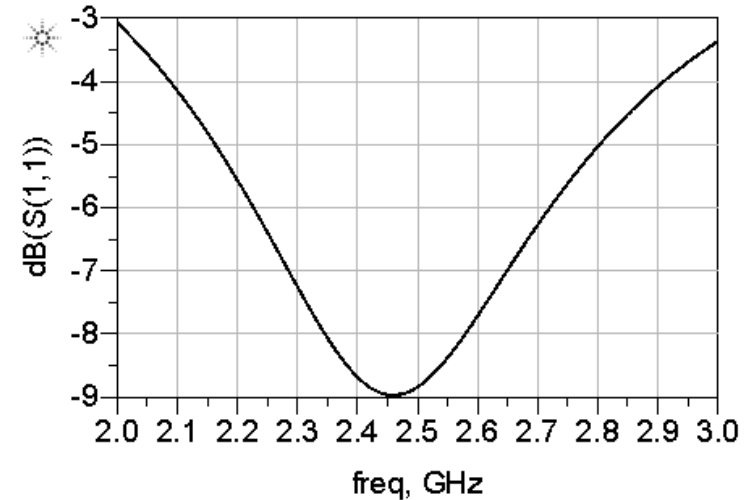

Radiation Patterns

- ▶ Gain -16dBi towards outside
- ▶ Gain -35 dBi in worst case position “through the head”

Max. gain (dBi)	Max. free space range R_{\max} (m)	Multipath error correction $\alpha = 0.6 R_{\max}$ (m)
-16	25	15

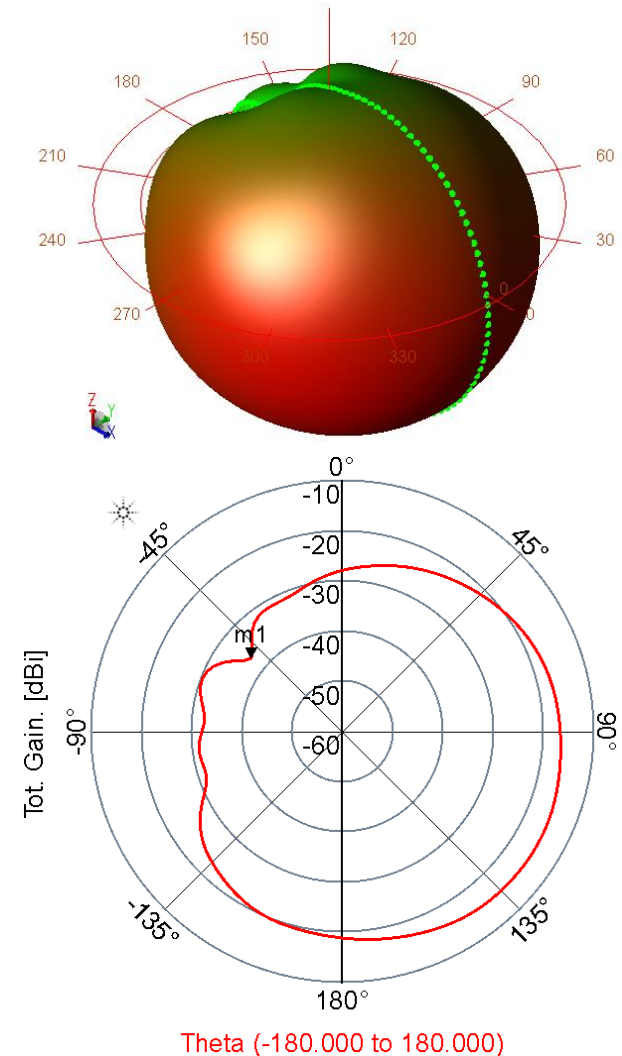

AGENDA

- ▶ *Insight SiP*
- ▶ *Introduction*
- ▶ *Metal Case Connected Watch*
 - *Metal Case Description*
 - *Design process*
 - *Design Example*
 - *Performance*
 - *Link Budget*
- ▶ *In-ear Hearing Aid*
 - *Design Example*
 - *Performance*
 - *Link Budget*
- ▶ **Conclusions**

Conclusions

- ▶ Design of Small Smart Bluetooth Antennas proven
- ▶ Take into account all material and size constraints
- ▶ Accept Link Budget compromise/tradeoff
- ▶ Connected metal watch range $\gg 10\text{m}$
- ▶ Hearing Aid range $> 1.5\text{m}$ worst case